

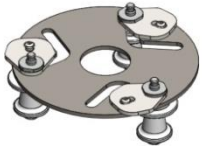

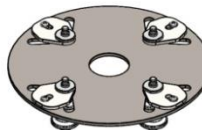







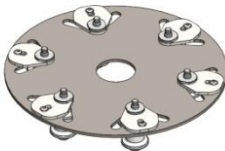

# ADAPTER DIMENSIONS

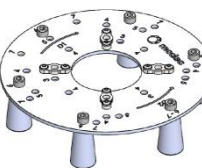
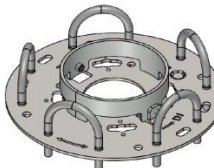
<p><a href="#">SA003</a></p> 	<p><a href="#">SA004</a></p> 	<p><a href="#">SA005</a></p> 	<p><a href="#">SA006</a></p> 	<p><a href="#">SA007</a></p> 	<p><a href="#">BJH &amp; RA30 with SA</a></p> 
<p><a href="#">BJH avec doigts SUA</a></p> 	<p><a href="#">SUA00X</a></p> 	<p><a href="#">FUA00X</a></p> 	<p><a href="#">FUA003/4/5/6</a></p> 	<p><a href="#">CSB003</a></p> 	<p><a href="#">CSB004</a></p> 
<p><a href="#">CSB005</a></p> 	<p><a href="#">SUA034</a></p> 	<p><a href="#">FSB 1/2</a></p> 	<p><a href="#">FSB 2/2</a></p> 	<p><a href="#">DC025</a></p> 	<p><a href="#">DC027</a></p> 
<p><a href="#">DC030</a></p> 	<p><a href="#">DC040</a></p> 	<p><a href="#">DC050</a></p> 	<p><a href="#">DC012-025</a></p> 	<p><a href="#">DC031-035</a></p> 	

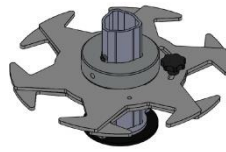
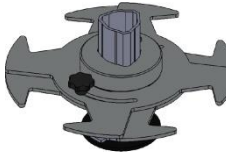
Released

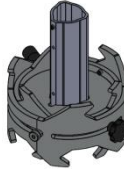
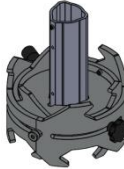
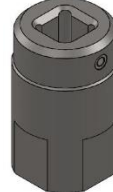
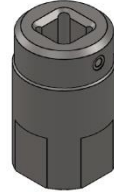
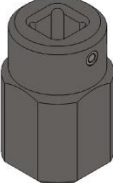
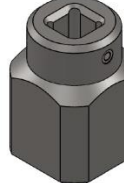
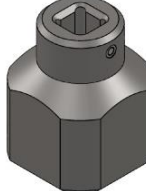
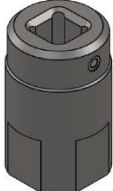
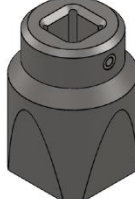

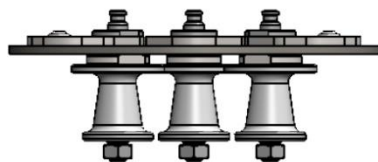
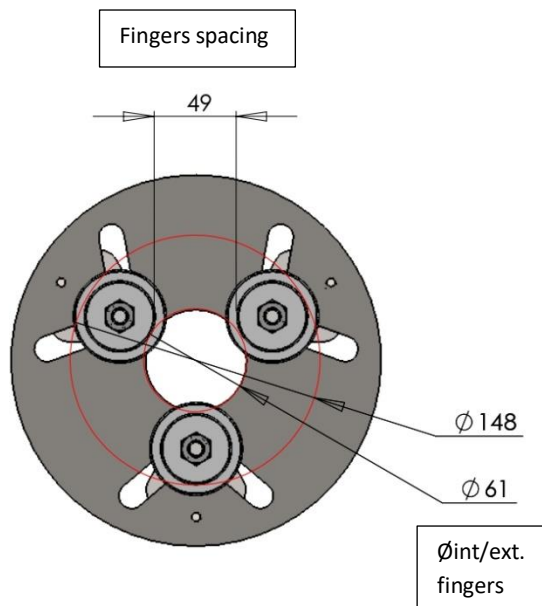
Weight : 2.3 Kg

# SA003

Operating

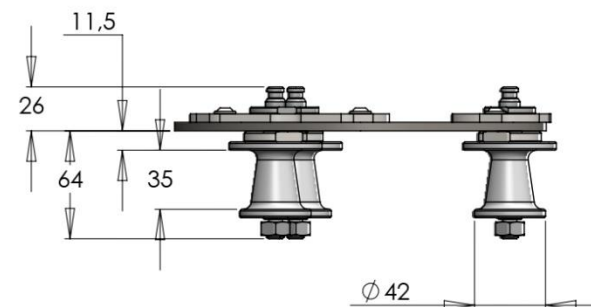
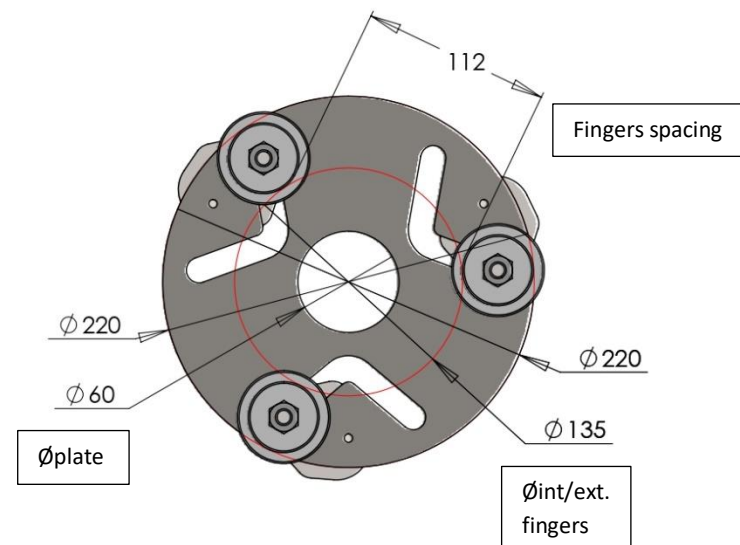

Others dimensions

Scale : 1:3

Released

# SA004

Operating

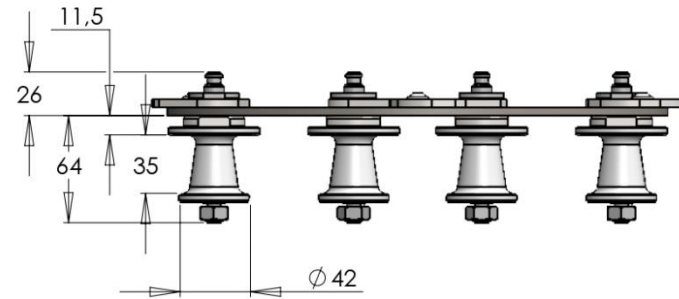
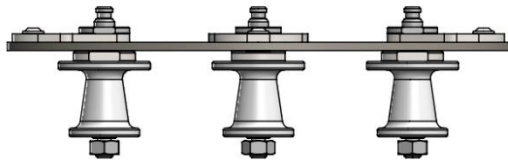
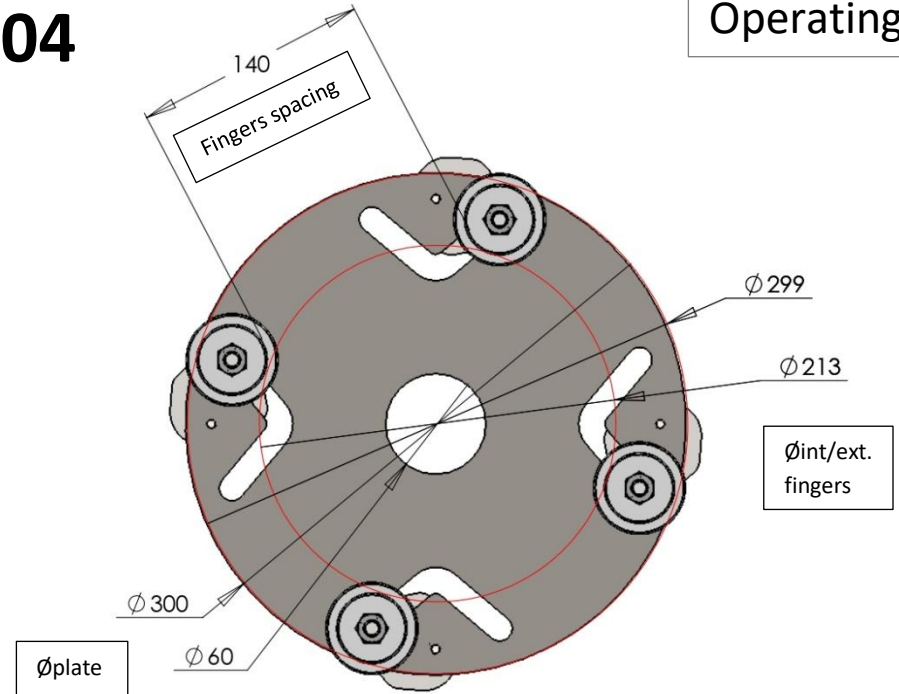
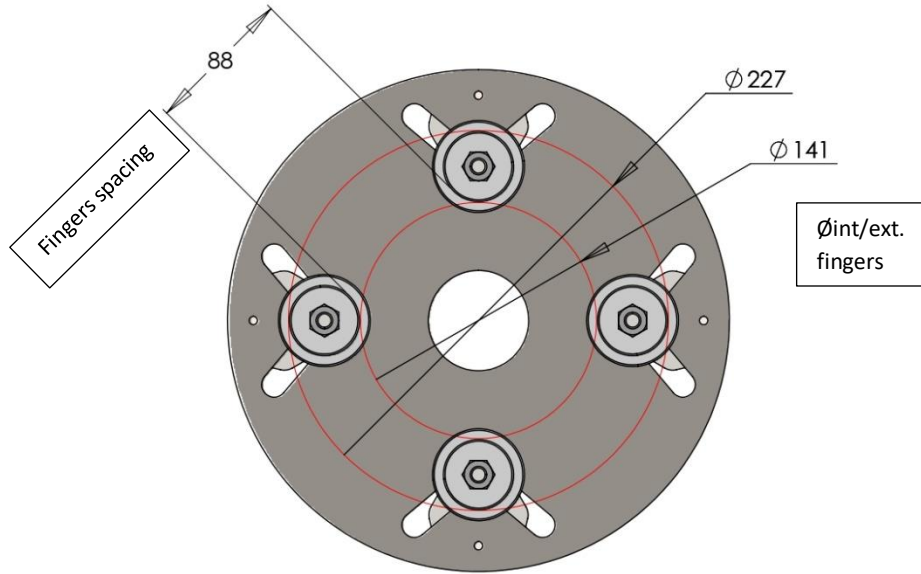

Weight : 4.1 Kg

Others dimensions

Scale : 1:3

Released

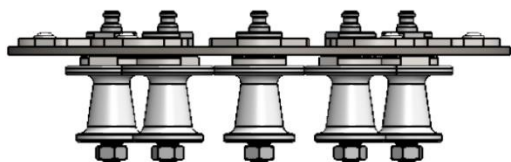
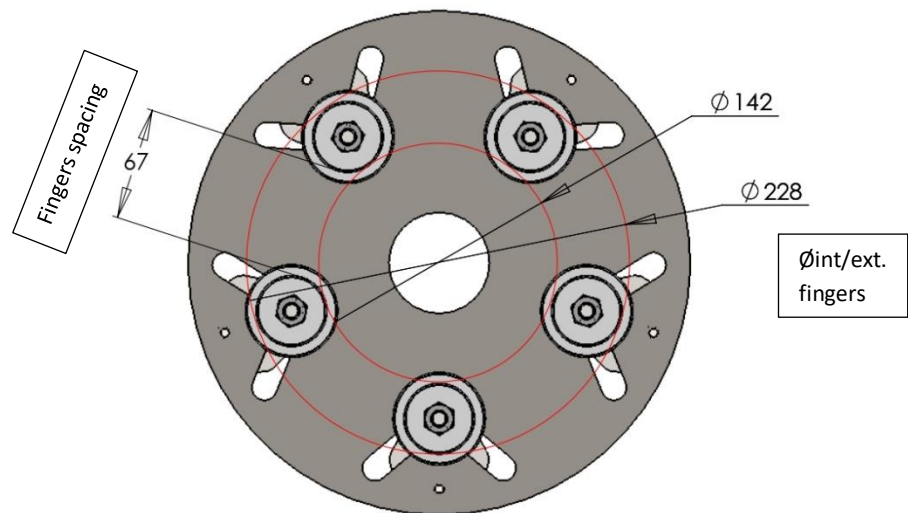

# SA005

Operating

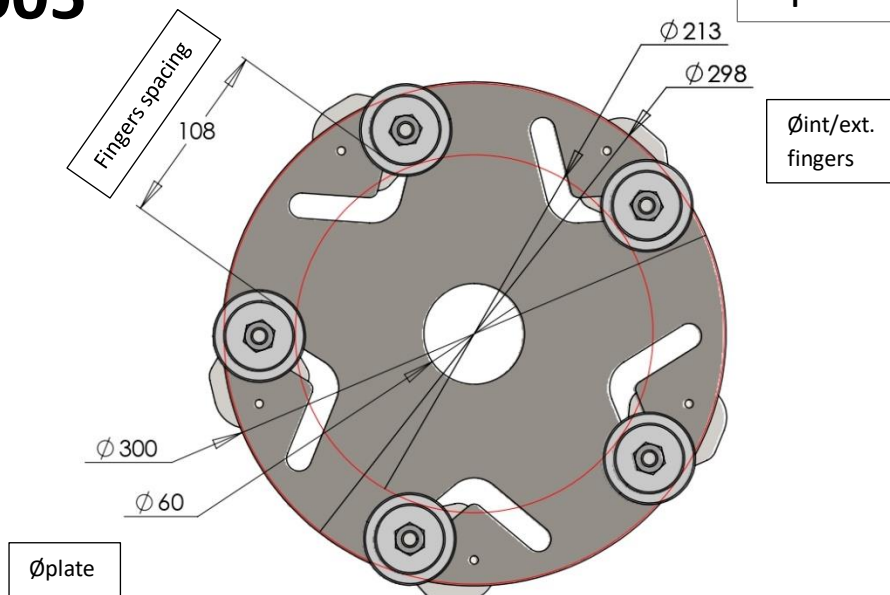

Øplate

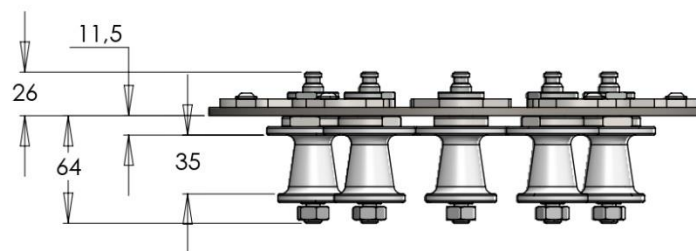

Others dimensions

Weight : 4.4 Kg

Scale : 1:3

Released

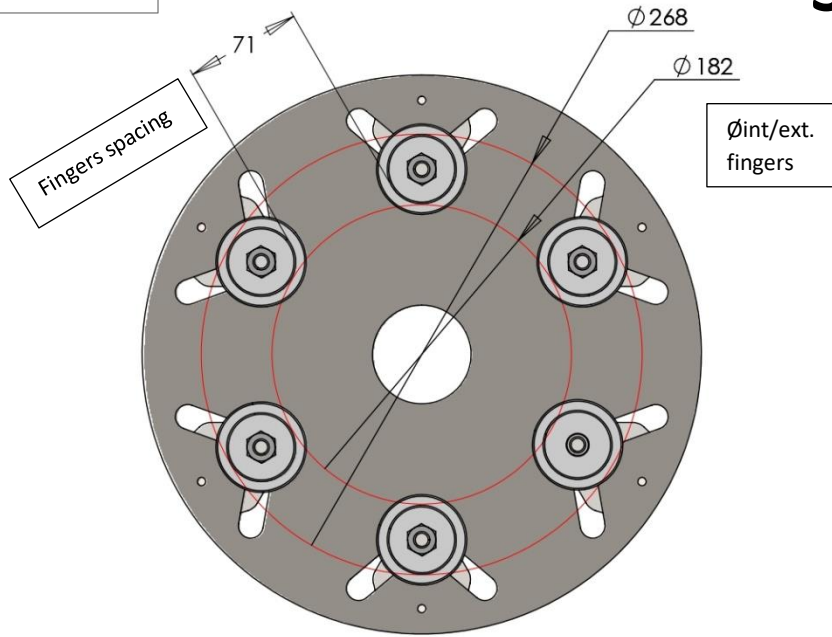

# SA006

Operating

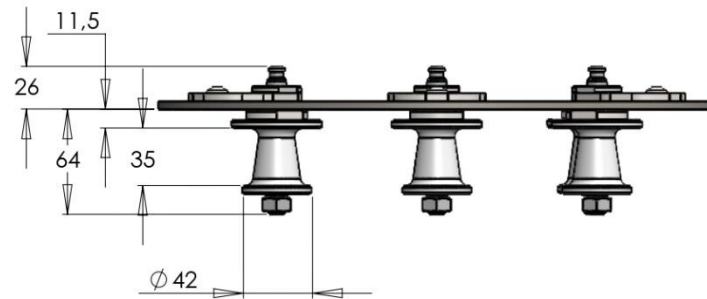
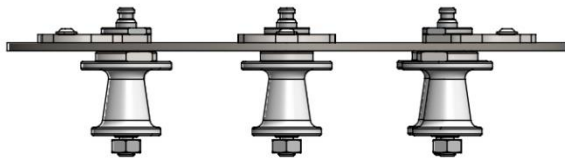
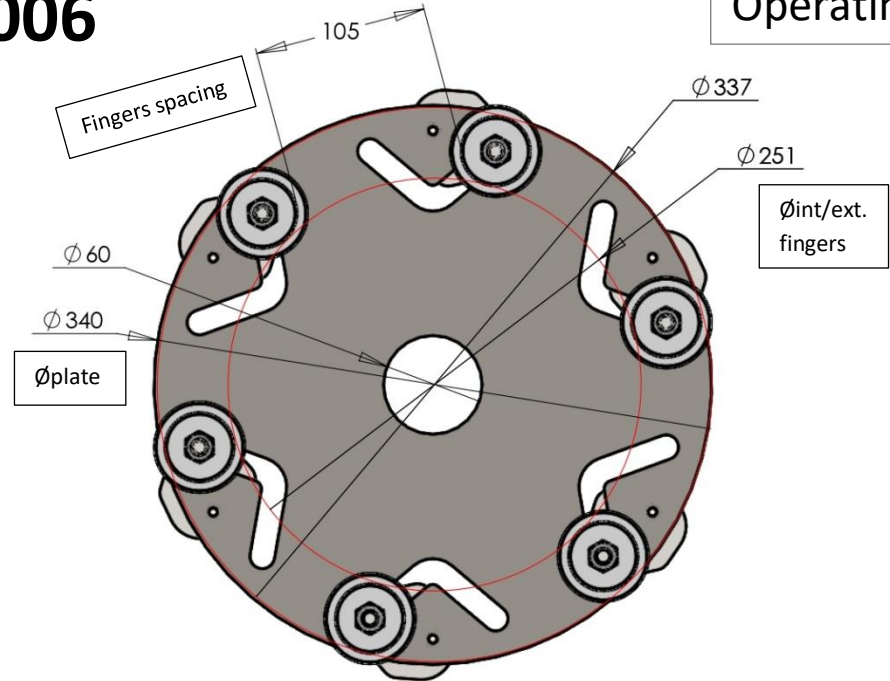

Others dimensions

Weight : 5.6 Kg

Scale : 1:3



Released

# SA007

Operating

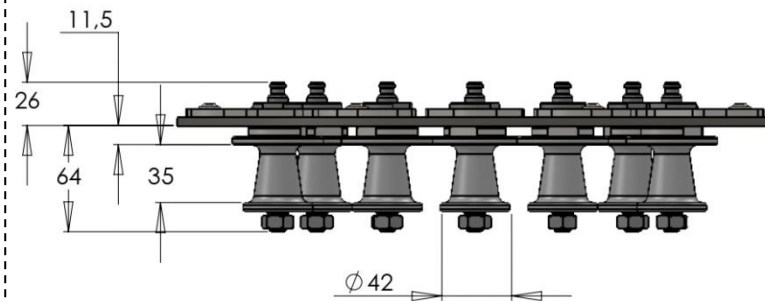
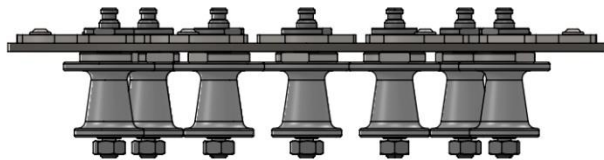
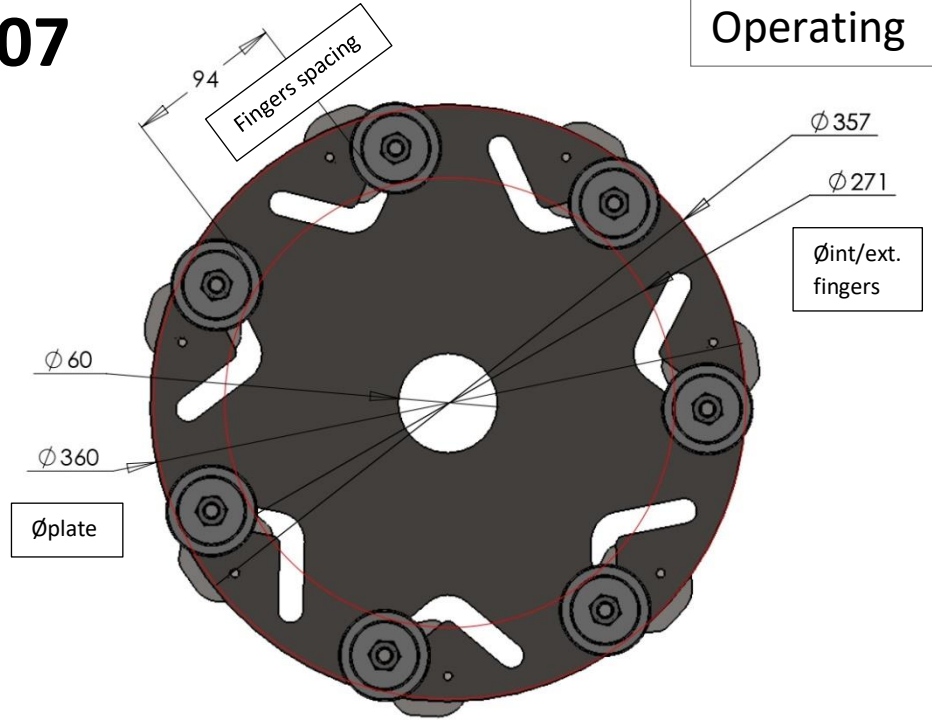
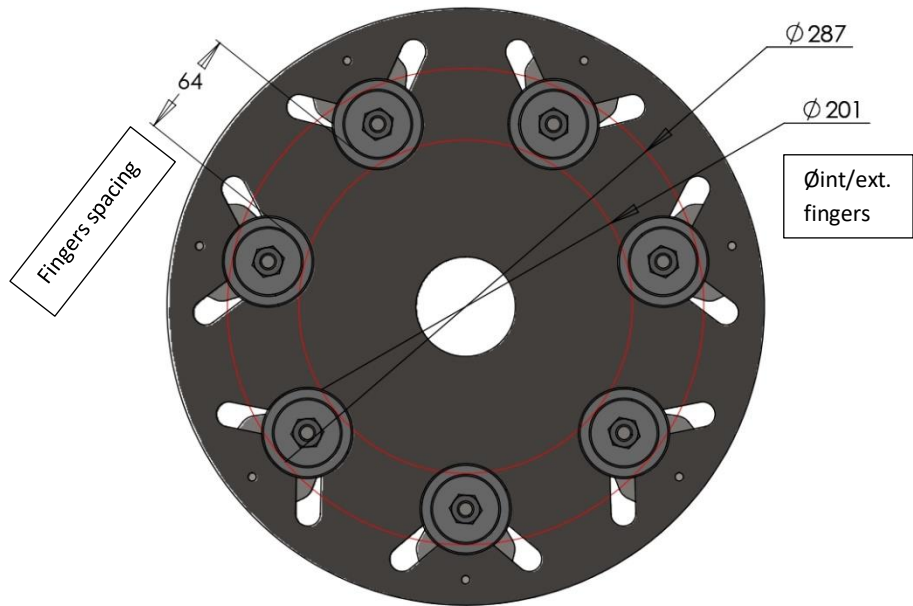

Others dimensions

Weight : 5.9 Kg

Scale : 1:3

# BJH01

With SA00X

BJH01 weight : 5 Kg

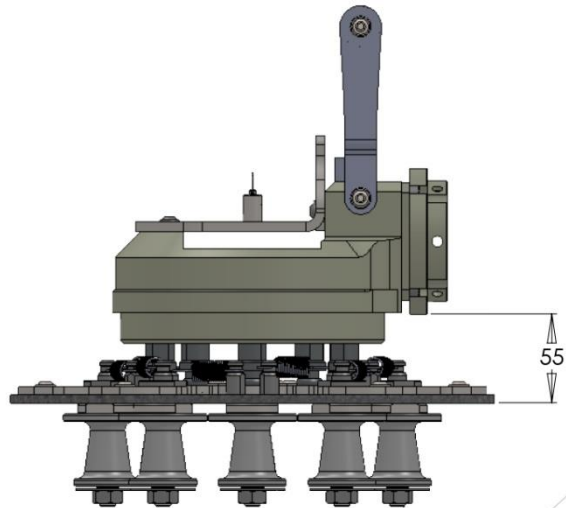

# BJH02

With SA00X

BJH02 weight : 8.6 Kg

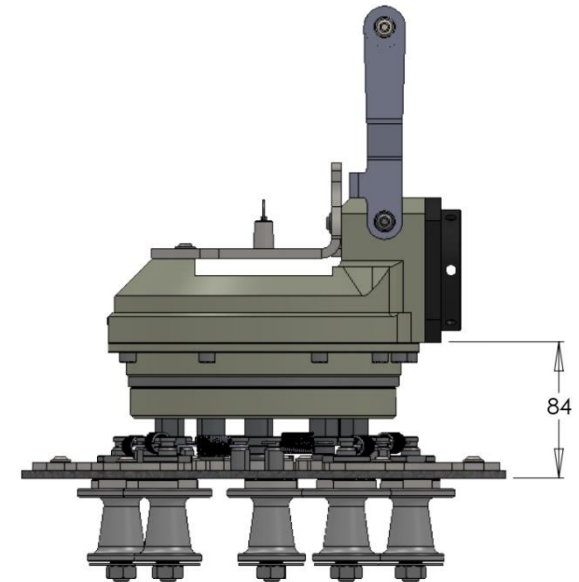

# RA30

With SA00X

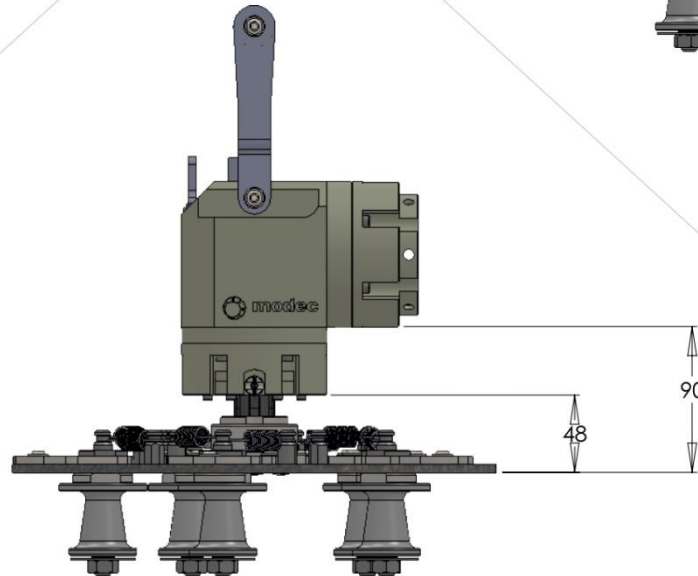

RA30 weight : 4.2 Kg

Scale : 1:3

# BJH00X

With SUA001

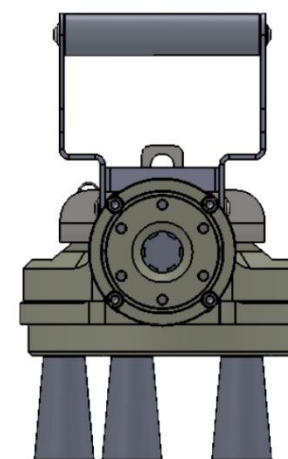
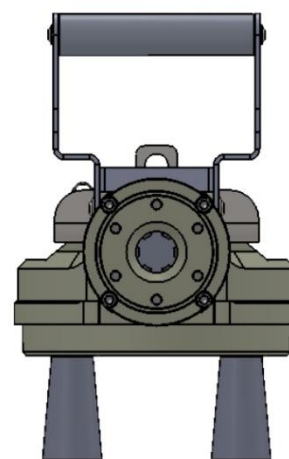
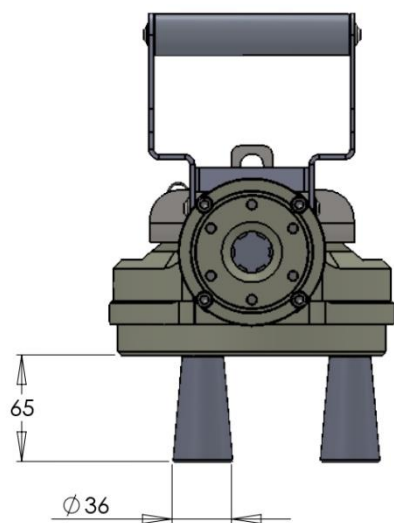
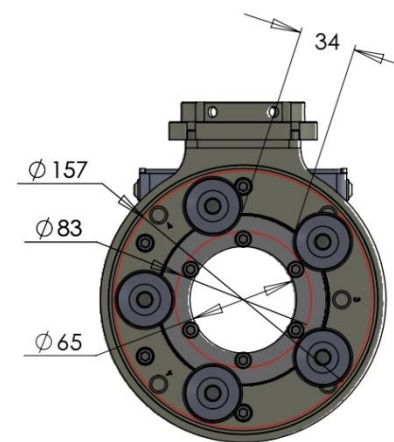
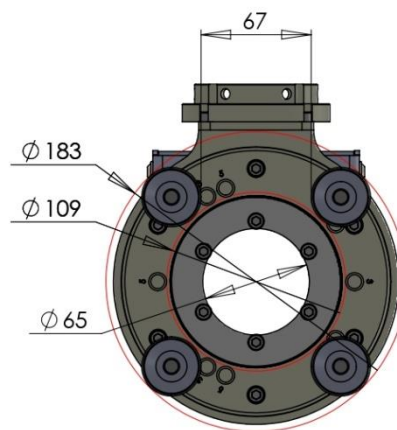
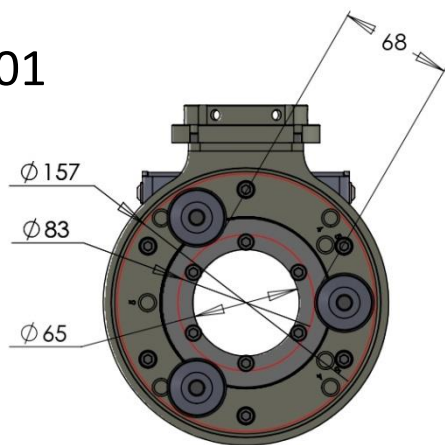

BJH01 weight : 5 Kg  
BJH02 weight : 8.6 Kg  
SUA001 weight : 0.3 Kg

Scale : 1:3



# SUA00X

With 3 or 4 fingers

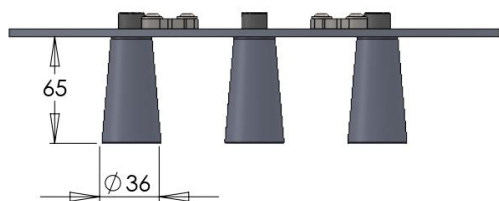
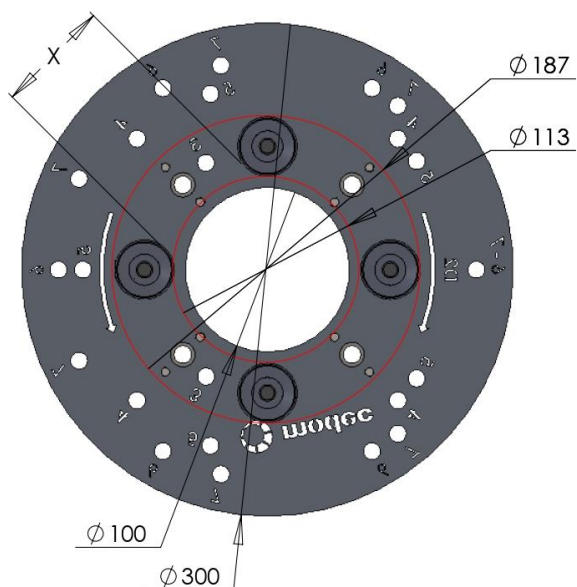

	3 fingers	4 fingers
X	93 mm	70 mm

With 4 or 5 fingers

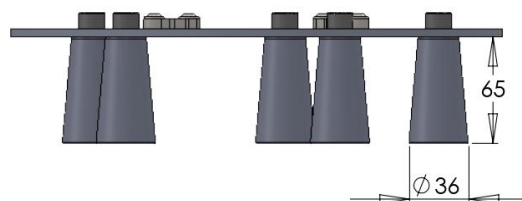
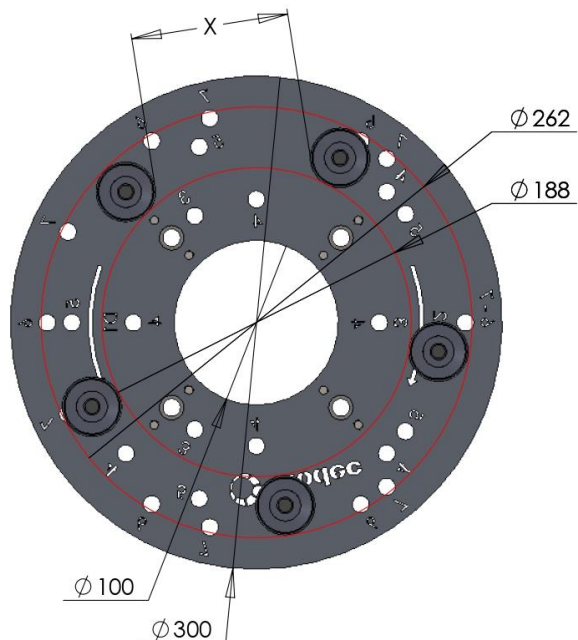

	4 fingers	5 fingers
X	123 mm	96 mm

With 6 or 7 fingers

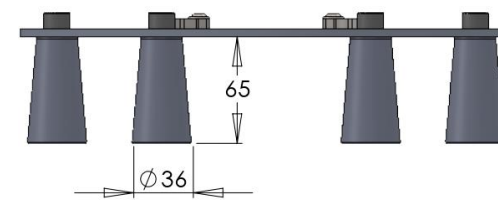
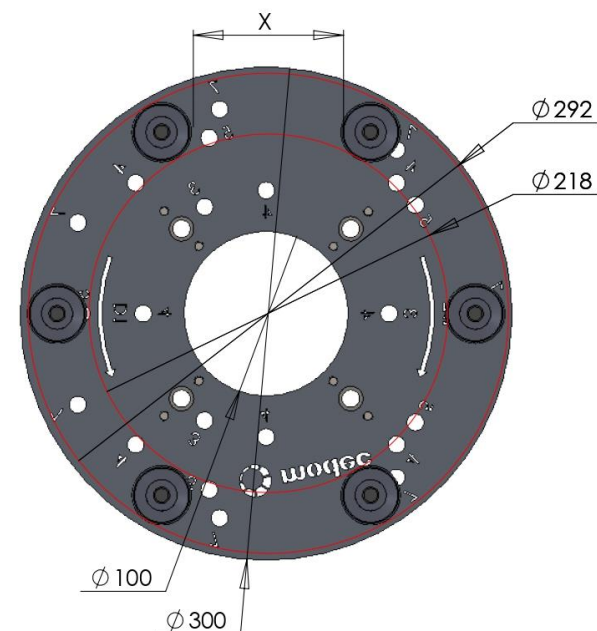

	6 fingers	7 fingers
X	91 mm	74 mm

**SUA007 weight : 5.2 Kg**  
**SUA001 weight : 0.3 Kg**

Scale : 1:3

# FUA00X

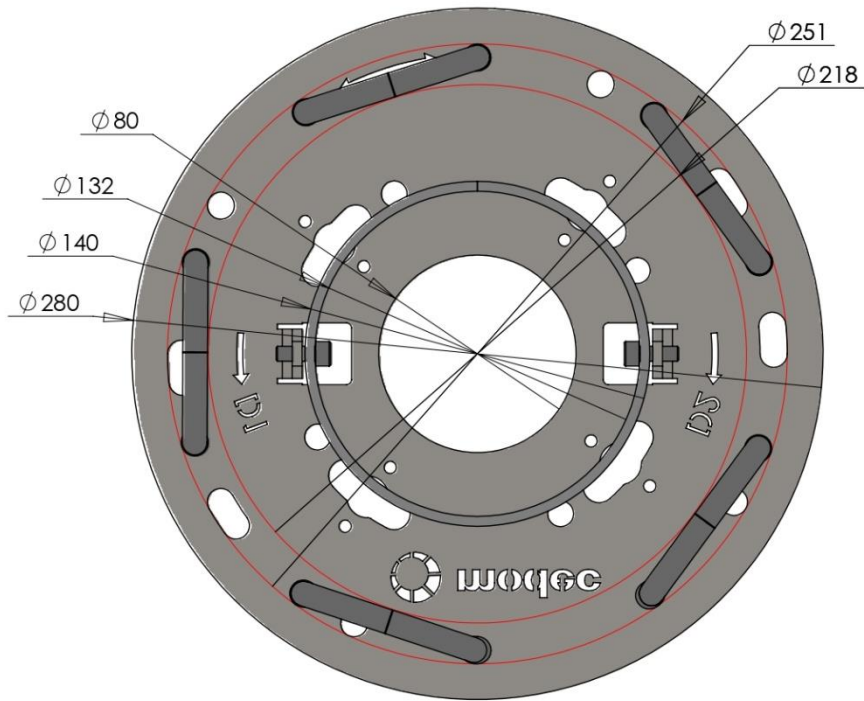

**FUA001 weight : 3.1 Kg**  
**FUA002 weight : 3.3 Kg**

## FUA001

	ØMax.
10°	37 mm
20°	43 mm
30°	47 mm

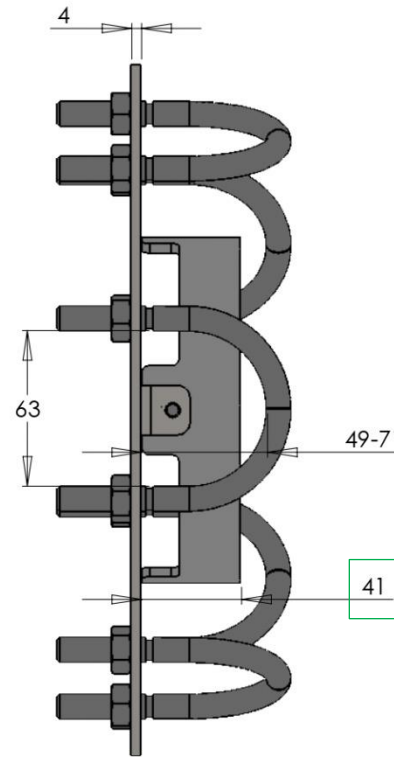

Width	Thick Max. (mm)
40 mm	10° : 30 / 20° : 36 / 30° : 41
50 mm	10° : 25 / 20° : 32 / 30° : 37
62 mm	10° : 13 / 20° : 19 / 30° : 26

## FUA002

	ØMax.
30°	30 mm
40°	35 mm

← Round arm →

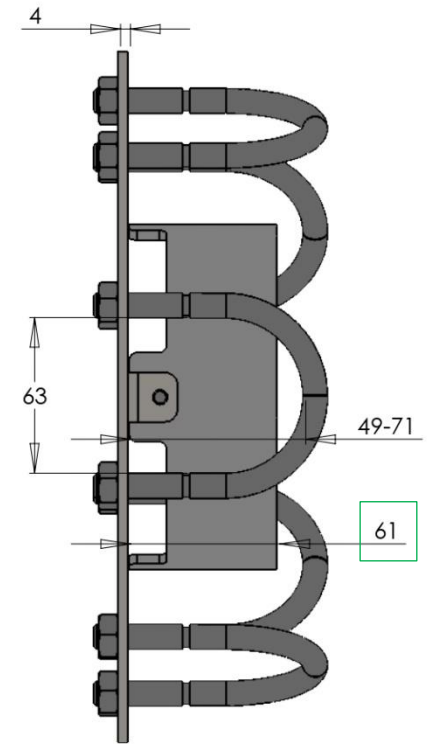

Width	Thick Max. (mm)
40 mm	30° : 24 / 40° : 30
50 mm	30° : 19 / 40° : 26
62 mm	30° : 8 / 40° : 15

← Square arm →

Scale : 1:2

[Return to home](#)

# FUA003/4/5/6

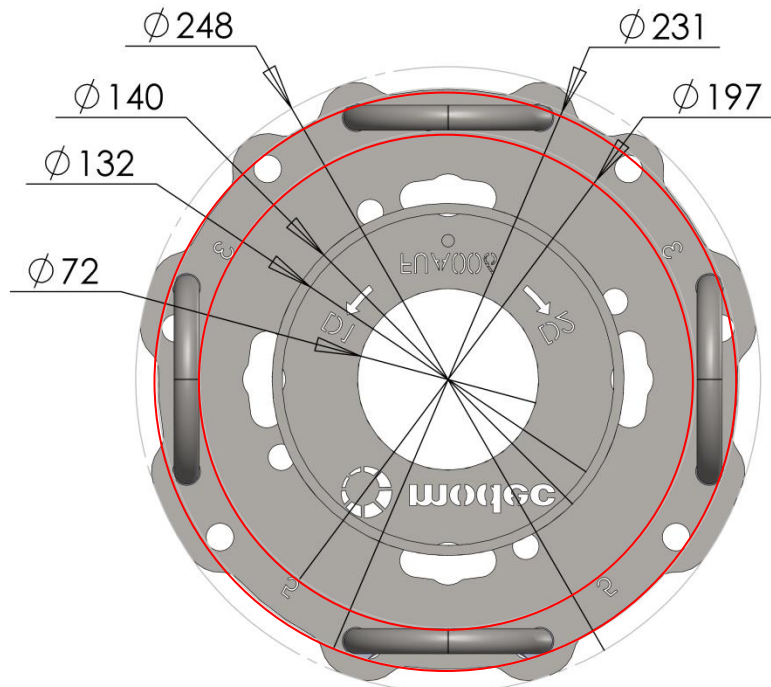

**FUA003**  
**FUA004**

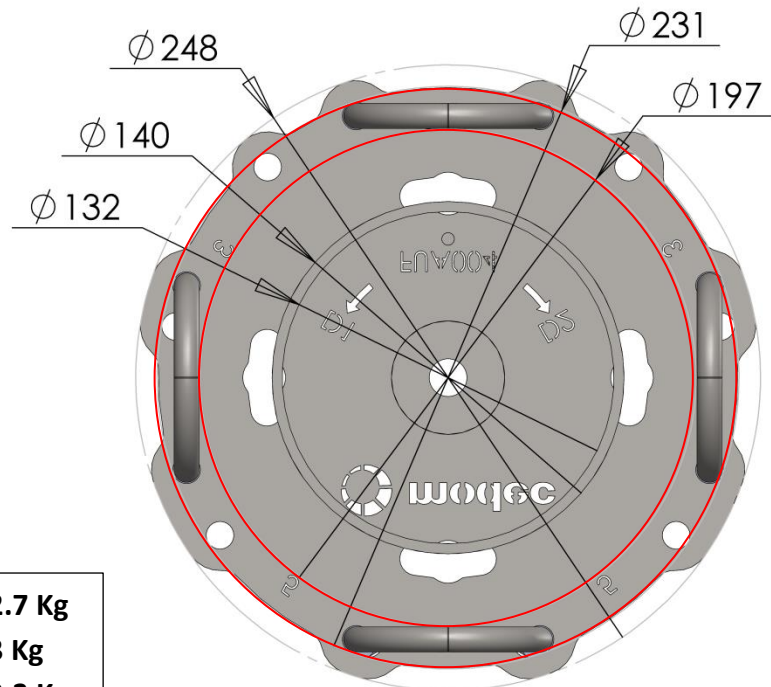

**FUA005**  
**FUA006**

**FUA003**  
**FUA005**

	ØMax.
0°	27 mm
10°	32 mm
20°	36 mm
30°	39 mm

← Round arm →

	ØMax.
30°	22 mm
40°	26 mm
50°	28 mm
55°	29 mm

**FUA004**  
**FUA006**

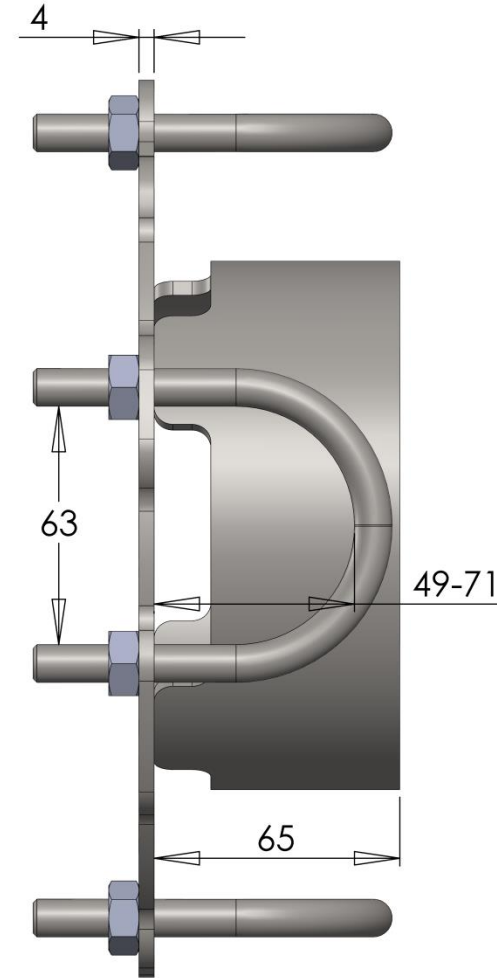
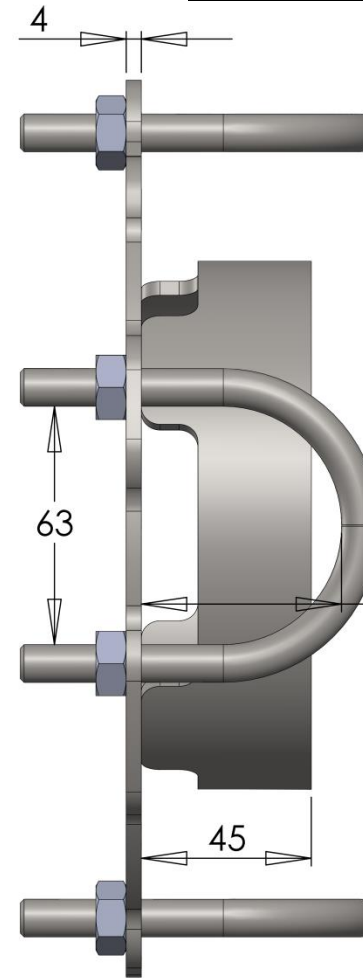

Width	Thick Max. (mm)			
	0°	10°	20°	30°
40 mm	19	25	30	33
50 mm	14	20	25	29
62 mm	0	7	12	18

← Square arm →

Width	Thick Max. (mm)			
	30°	40°	50°	55°
40 mm	16	20	24	25
50 mm	12	17	21	0
62 mm	0	7	13	0

**FUA003 weight : 2.7 Kg**  
**FUA004 weight : 3 Kg**  
**FUA005 weight : 2.3 Kg**  
**FUA006 weight : 2.6 Kg**

Scale : 1:3

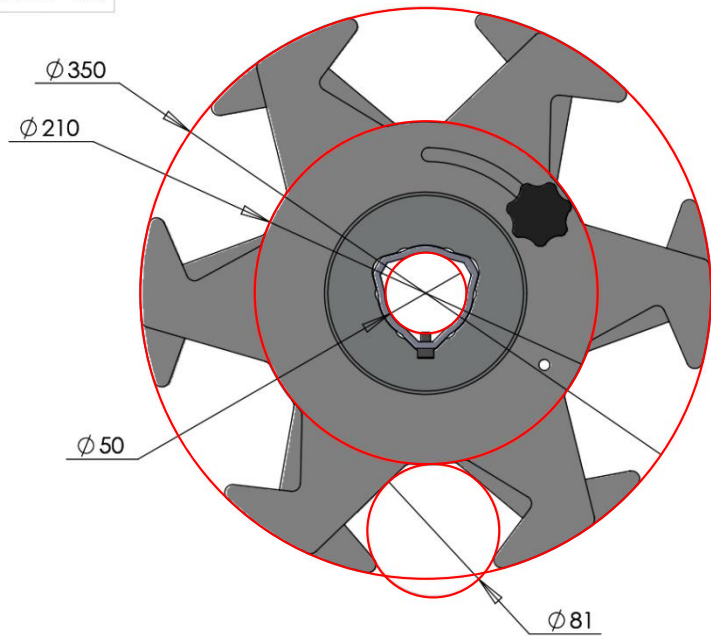

# CSB003

ØMax for a vertical cylindrical arm

Scale : 1:1

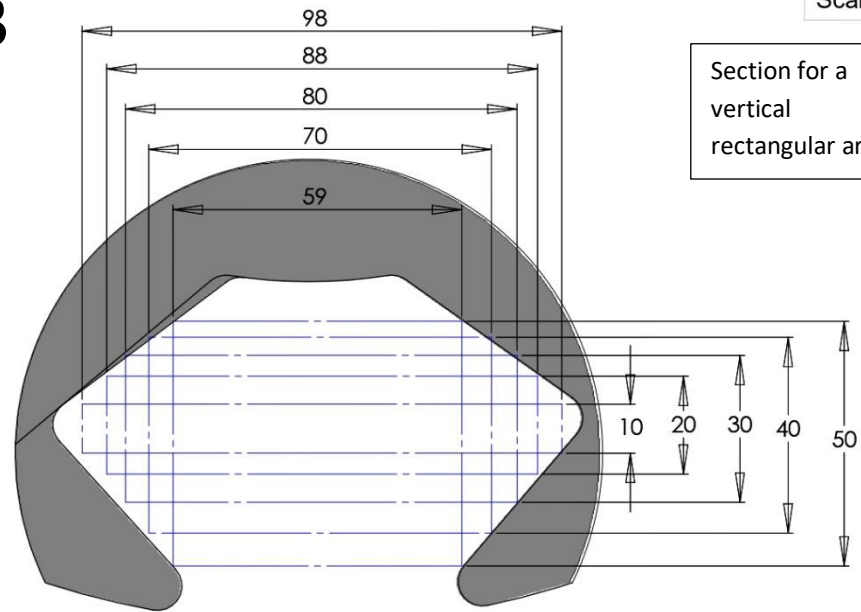

Section for a vertical rectangular arm

Scale : 1:3

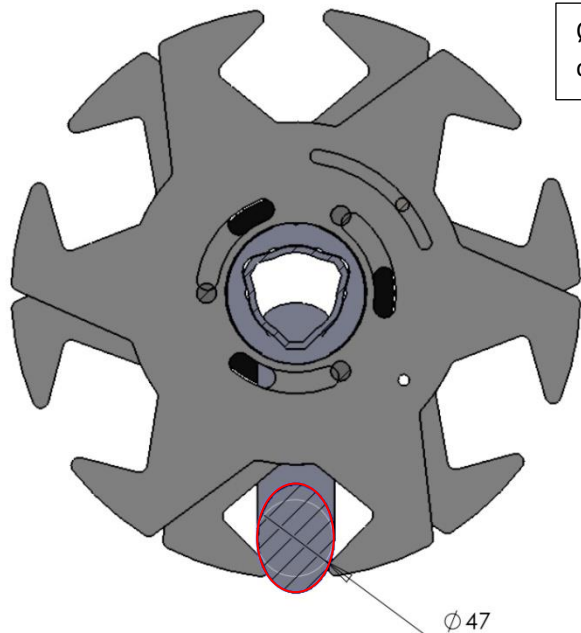

ØMax for a 45° cylindrical arm

Scale : 1:1

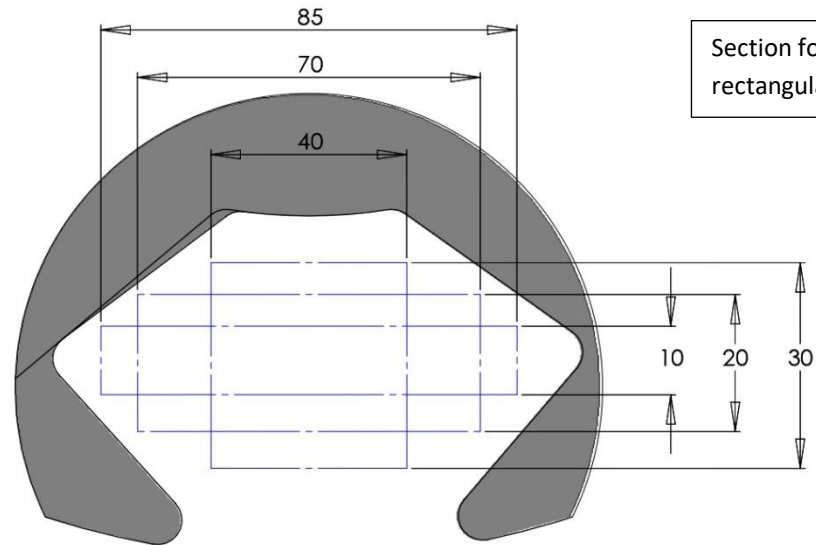

Section for a 45° rectangular arm

weight : CSBxxx-20 : 4.2 Kg ; CSBxxx-40 : 5.2 Kg  
CSBxxx-60 : 6.6 Kg



Scale : 1:3

# CSB004

Scale : 1:1

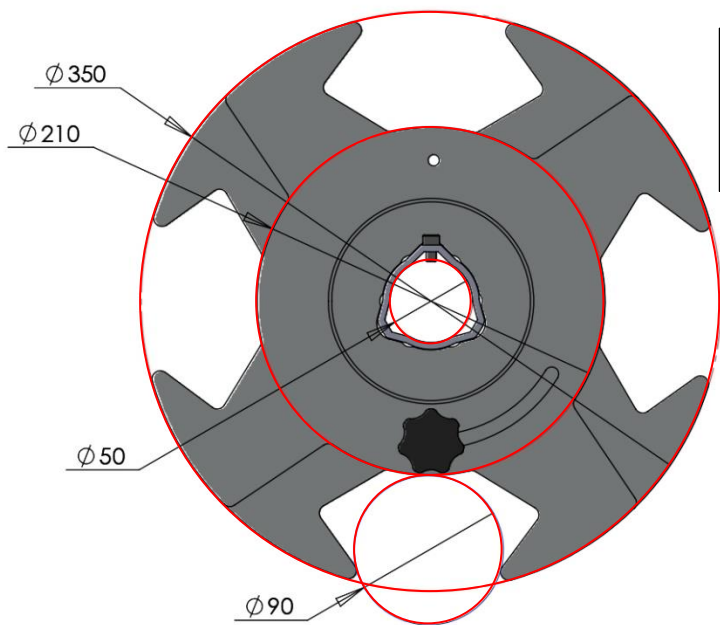

$\phi$ Max for a vertical cylindrical arm

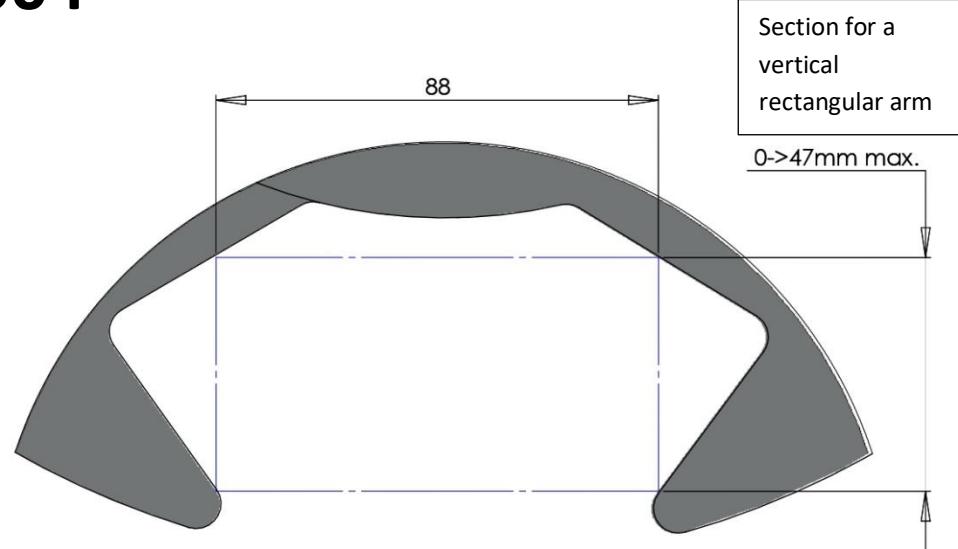

Section for a vertical rectangular arm

0->47mm max.

Scale : 1:3

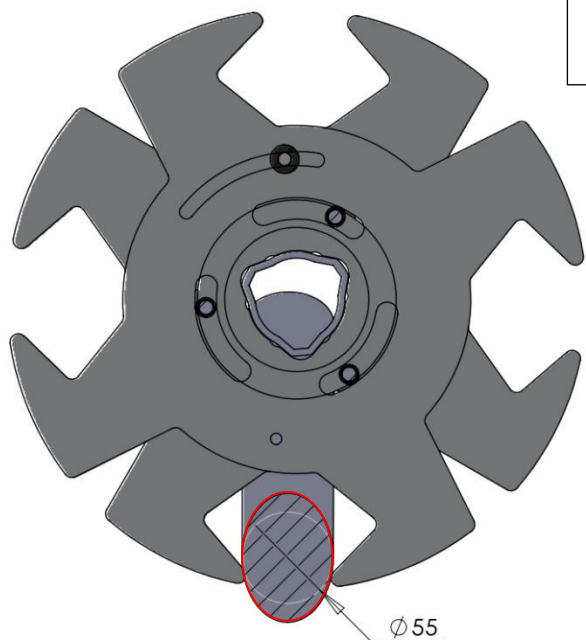

$\phi$ Max for a 45° cylindrical arm

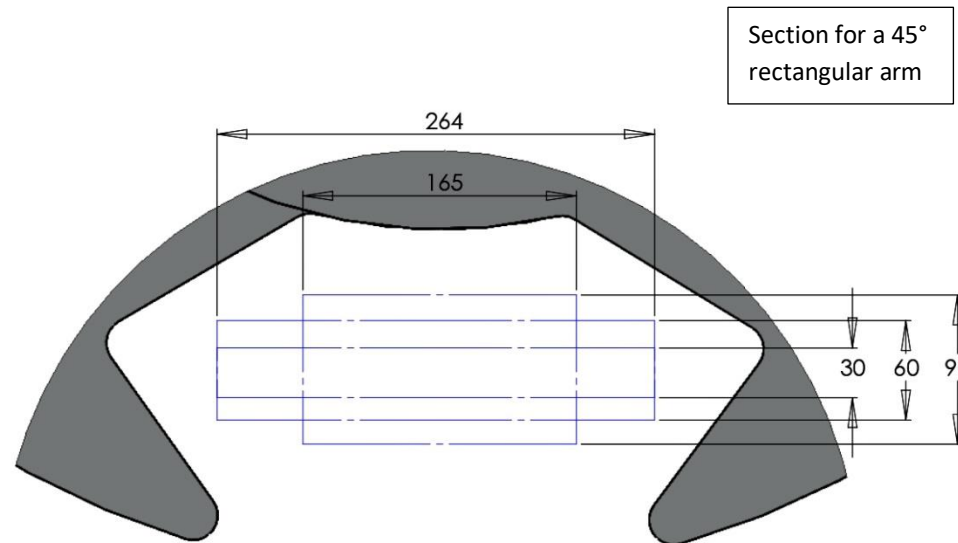

Section for a 45° rectangular arm

weight : CSBxxx-20 : 4.2 Kg ; CSBxxx-40 : 5.2 Kg  
CSBxxx-60 : 6.6 Kg

Scale : 1:1



Scale : 1:3

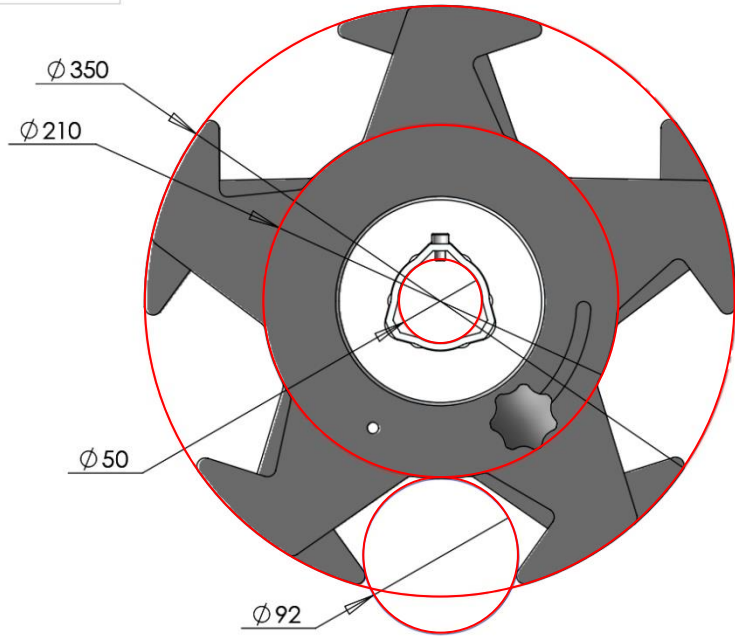

# CSB005

Scale : 1:1

ØMax for a vertical cylindrical arm

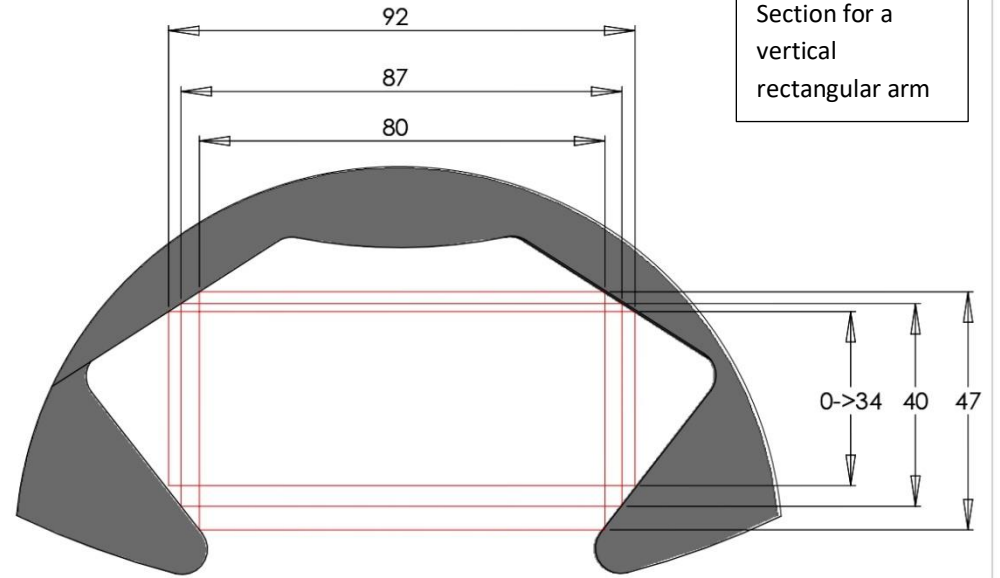

Section for a vertical rectangular arm

Scale : 1:3

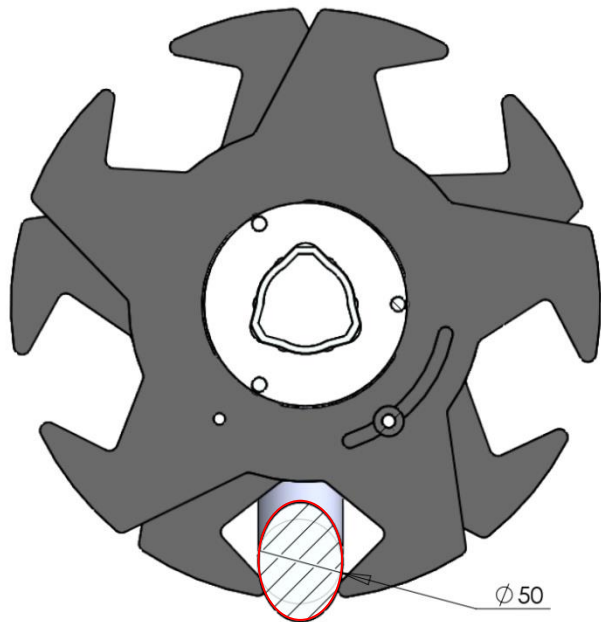

ØMax for a 45° cylindrical arm

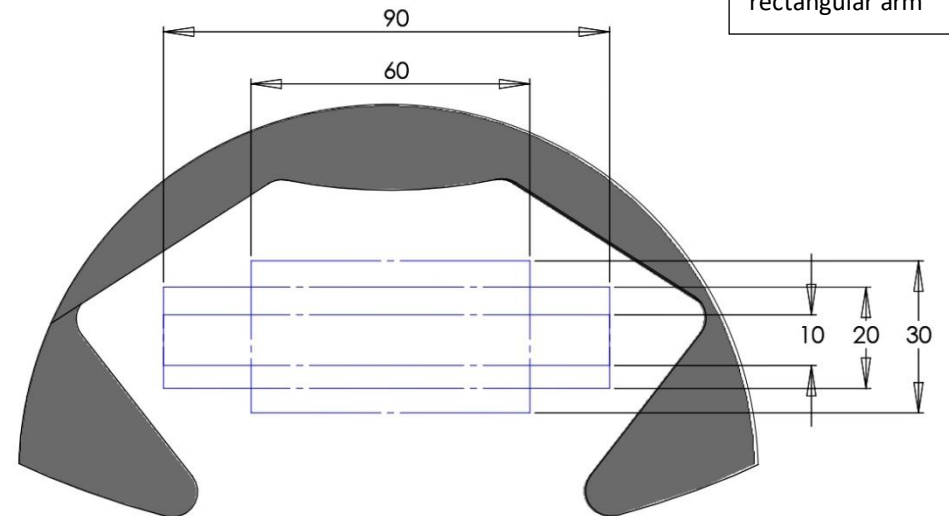

Section for a 45° rectangular arm

weight : CSBxxx-20 : 4.2 Kg ; CSBxxx-40 : 5.2 Kg  
CSBxxx-60 : 6.6 Kg

Scale : 1:1

# SUA034

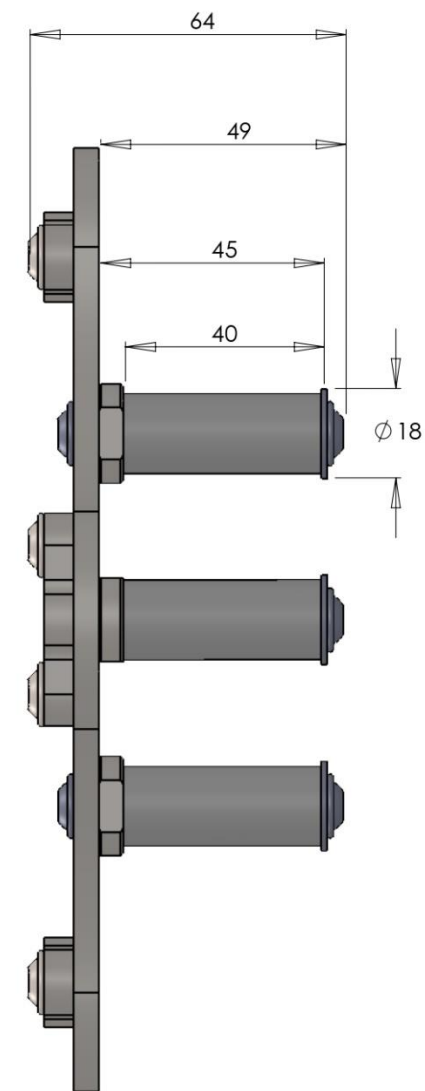
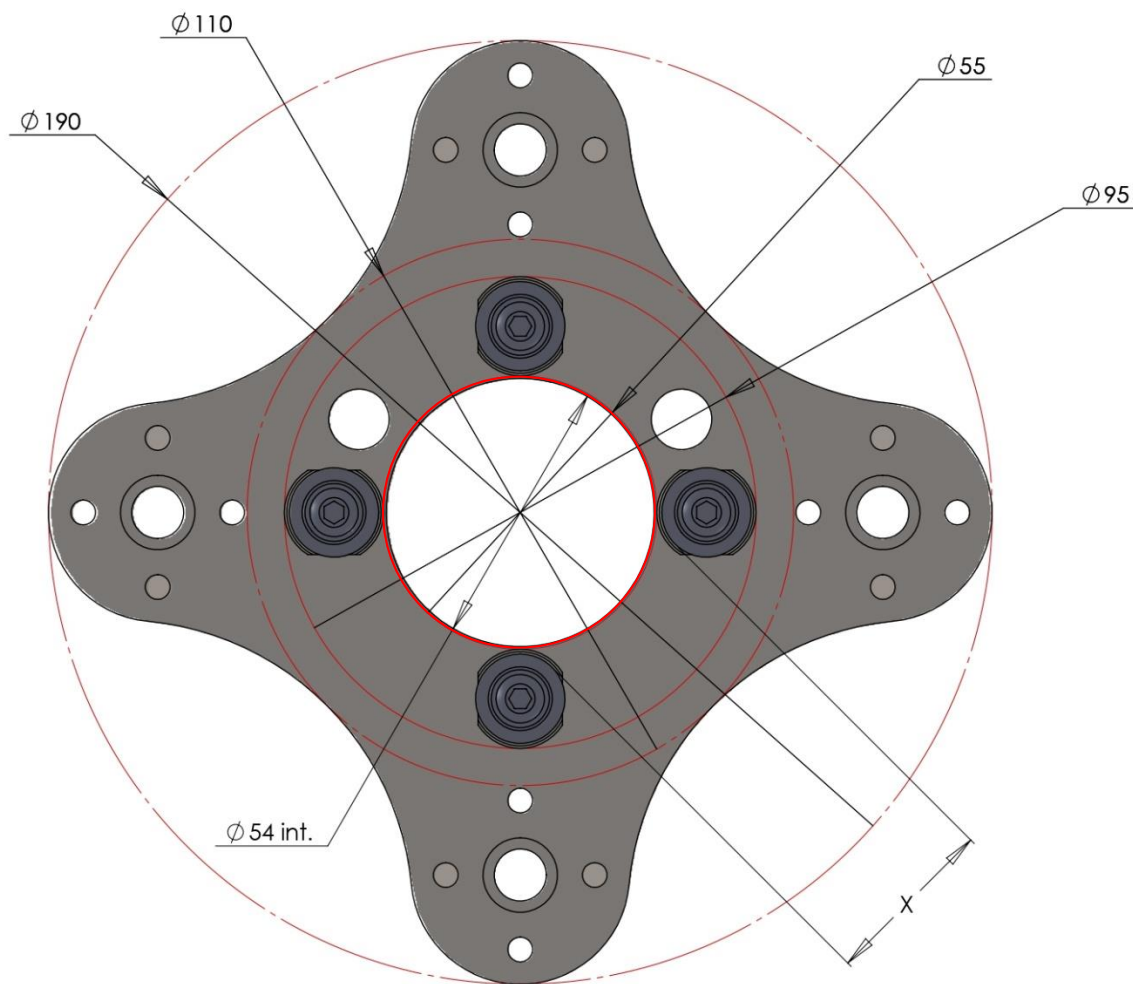

	3 fingers	4 fingers
X	47 mm	35 mm

weight : 0.8 Kg

Scale : 1:1

# FSB (P1/2)

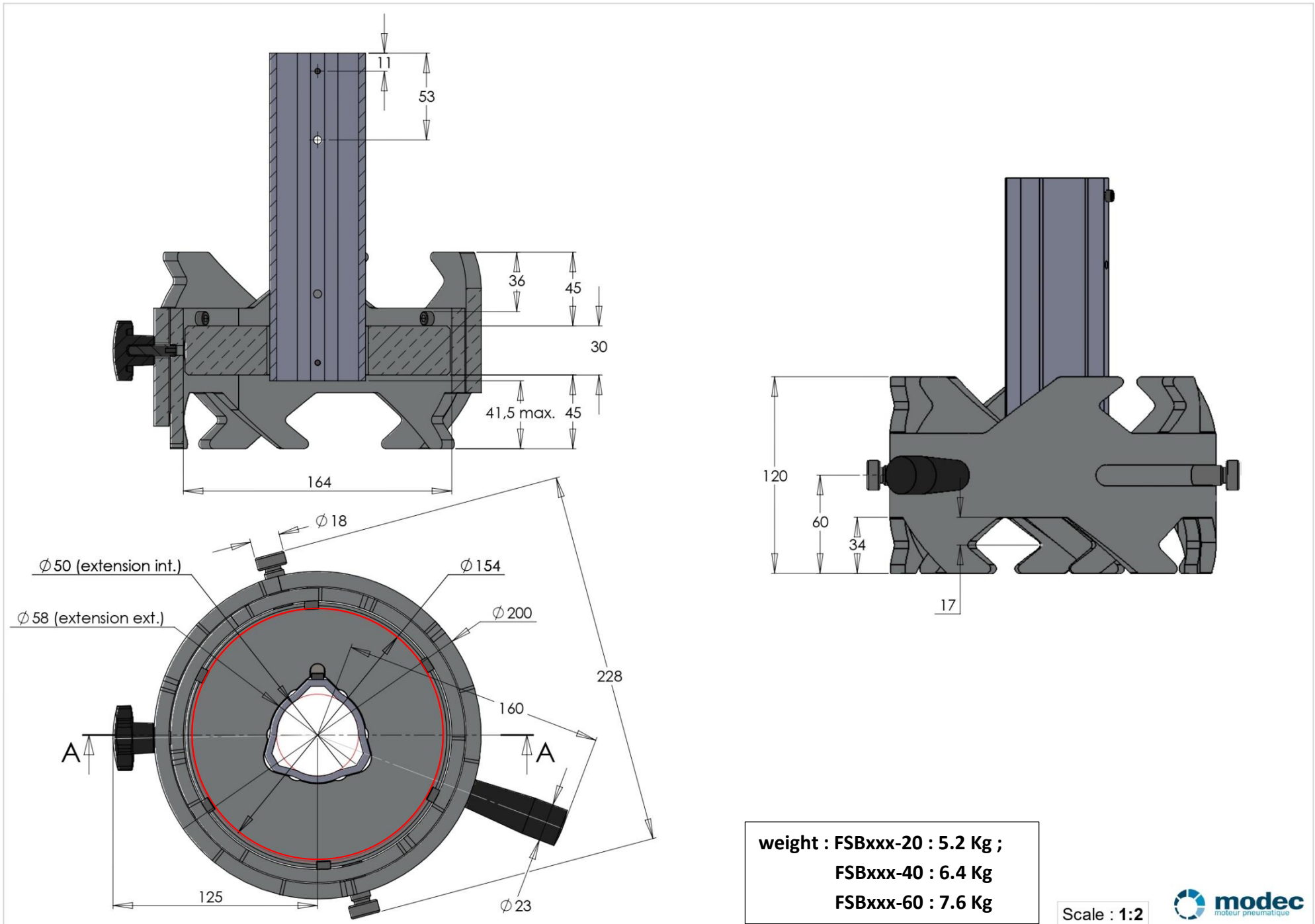

# FSB (P2/2)

Scale : 2:3

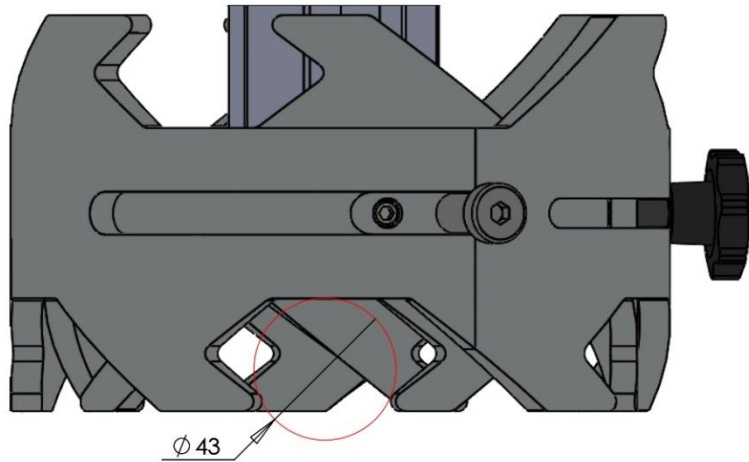

$\varnothing$ Max for a horizontal cylindrical arm

Scale : 1:1

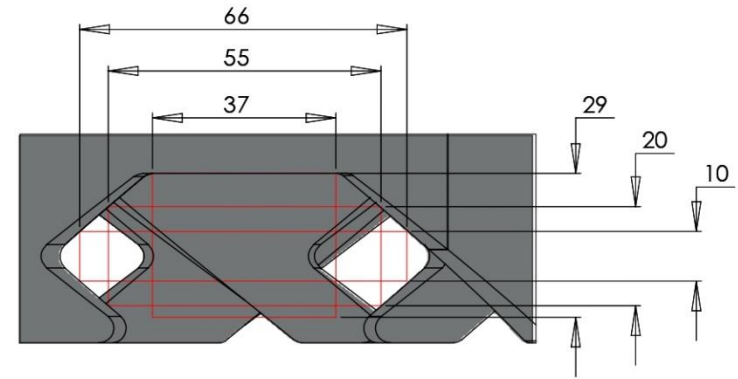

Section for a horizontal rectangular arm

$\varnothing$ Max for a 30° cylindrical arm

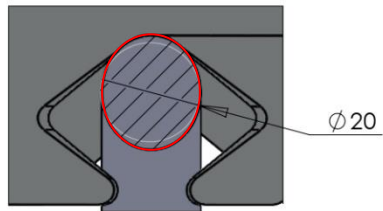

Section for a 30° rectangular arm

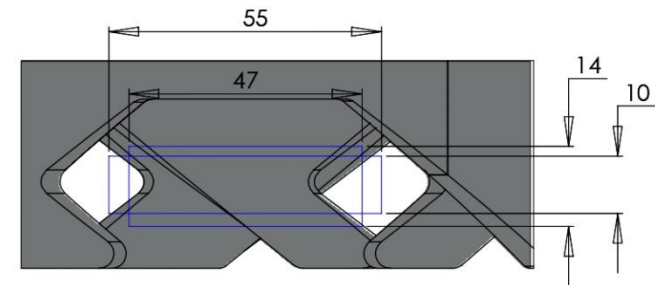

weight : FSBxxx-20 : 5.2 Kg ;  
FSBxxx-40 : 6.4 Kg  
FSBxxx-60 : 7.6 Kg

Scale : 1:1

Scale : 1:1

[Return to home](#)

# DC025

This socket can be used to rotate a square shaft of 25 mm (24~26 accepted)

Square depth : 40mm

weight : 0.9 Kg



# DC027

This socket can be used to rotate a square shaft of 27 mm (26~28 accepted)

Square depth : 40mm

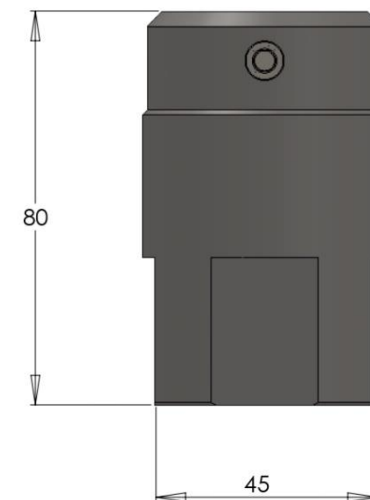
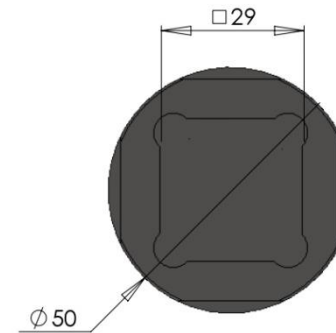

weight : 0.8 Kg

Scale : 1:1

# DC030

This socket can be used to rotate a square shaft of 30mm (29~31 accepted)

Square depth : 40mm

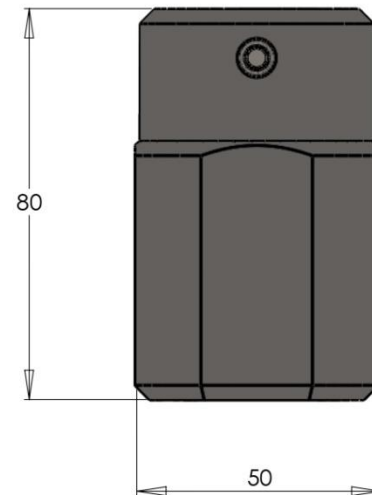
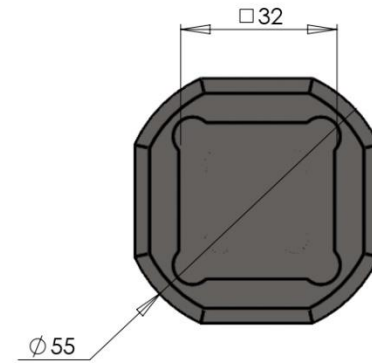

weight : 0.9 Kg

Scale : 1:1

# DC040

This socket can be used to rotate a square shaft of 40mm (38~40 accepted)

Square depth : 40mm

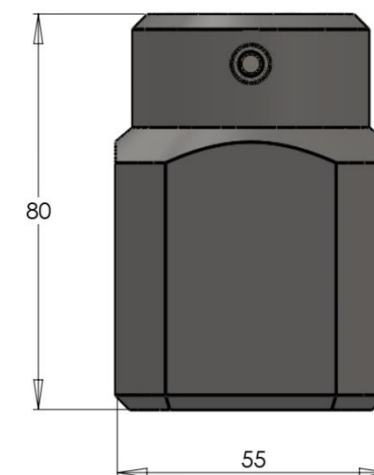
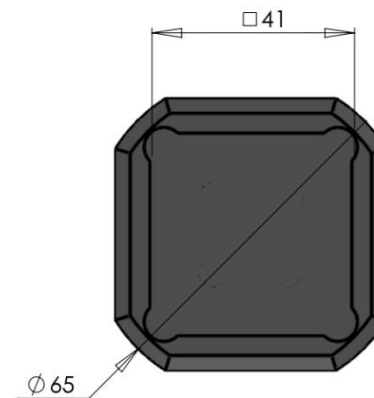

weight : 1 Kg

Scale : 1:1

# DC050

This socket can be used to rotate a square shaft of 50 mm (49~51 accepted)

Square depth : 50mm

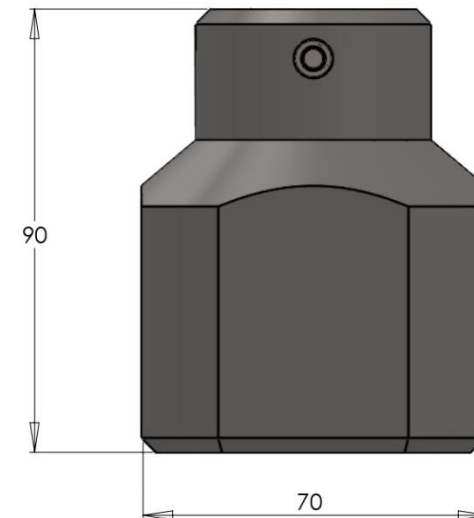
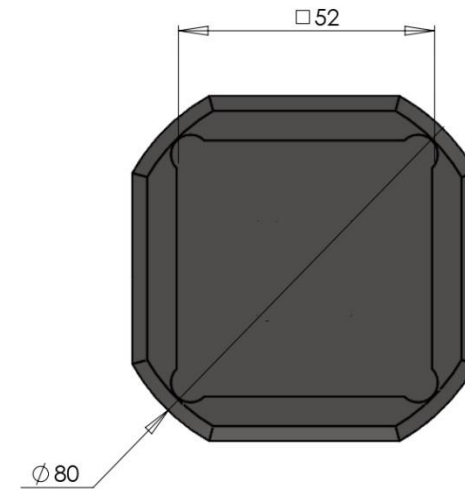

weight : 1.3 Kg

Scale : 1:1

# DC012-025

This socket can be used to rotate a square conical shaft. For dimensions : see drawing

Square depth : see drawing

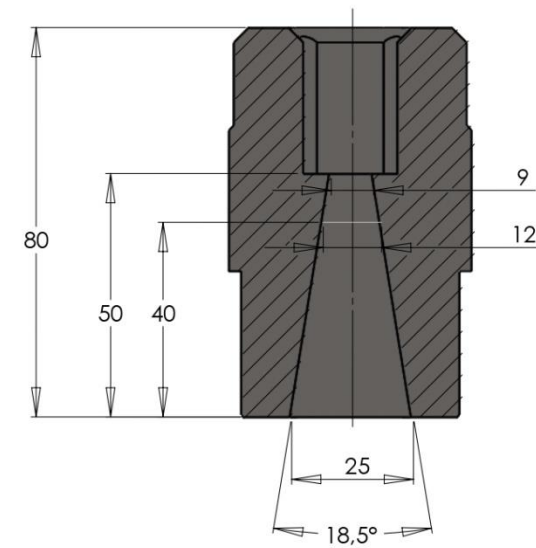
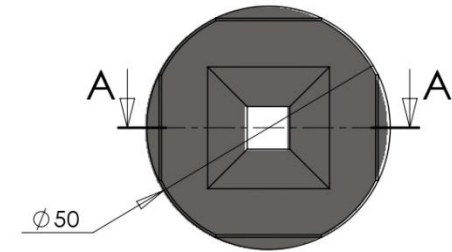

COUPE A-A

weight : 1 Kg

Scale : 1:1



# DC031-035

This socket can be used to rotate a square conical shaft. For dimensions : see drawing

Square depth : see drawing

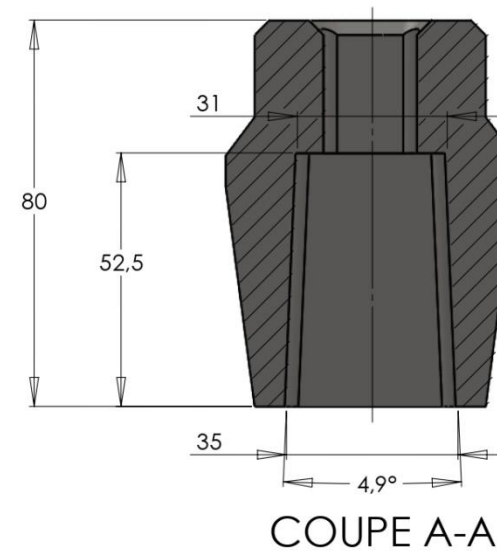
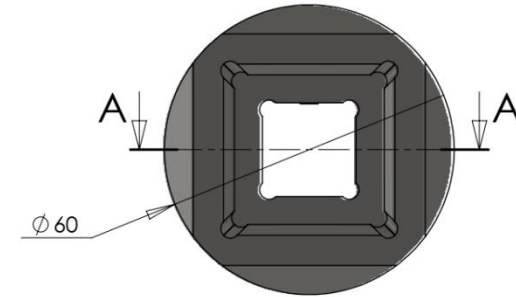

weight : 0.9 Kg

Scale : 1:1